

Support Unit

Models EK, BK, FK, EF, BF and FF

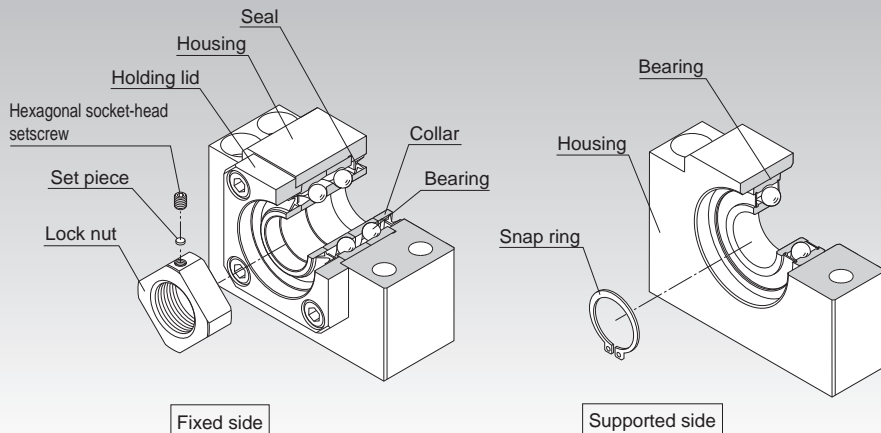

Fig.1 Structure of the Support Unit

Structure and Features

The support unit comes in six types: models EK, FK, EF, and FF, which are tailored to model BNK precision ball screw with finished shaft ends, and models BK and BF, which are standardized for general ball screws.

The support unit on the fixed side includes a JIS Class 5-compliant angular bearing provided with an adjusted preload.

The Support Unit on the supported side uses a deep-groove ball bearing.

The internal bearings of the Support Unit models EK, FK and BK contain an appropriate amount of lithium soap-group grease that is sealed with a special seal. Thus, these models are capable of operating over a long period.

[Uses the Optimal Bearing]

To ensure the rigidity balance with the Ball Screw, the Support Unit uses an angular bearing (contact angle: 30°; DF configuration) with a high rigidity and a low torque. Miniature Support Unit models EK/FK 4, 5 and 6 are incorporated with a miniature angular bearing with a contact angle of 45° developed exclusively for miniature Ball Screws. This bearing has a greater contact angle of 45° and an increased number of balls with a smaller diameter. The high rigidity and accuracy of the miniature angular bearing provides the stable rotational performance.

[Support Unit Shapes]

The square and round shapes are available for the Support Unit to allow the selection according to the intended use.

Example of Installation

Square Type

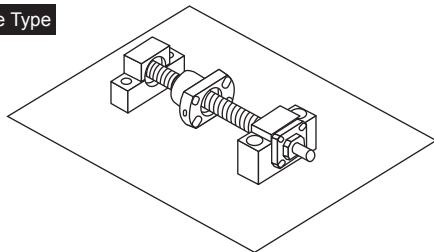

Round Type

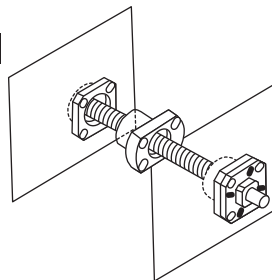
**[Compact and Easy Installation]**

The Support Unit is compactly designed to accommodate the space in the installation site. As the bearing is provided with an appropriately adjusted preload, the Support Unit can be assembled with a Ball Screw unit with no further machining. Accordingly, the required man-hours in the assembly can be reduced and the assembly accuracy can be increased.

Type

[For the Fixed Side]

Square Type Model EK

Specification Table⇒ **A** 15-282

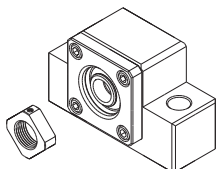

(Inner diameter: $\phi 4$ to $\phi 20$)

Square Type Model BK

Specification Table⇒ **A** 15-284

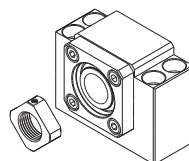

(Inner diameter: $\phi 10$ to $\phi 40$)

Round Type Model FK

Specification Table⇒ **A** 15-286

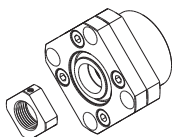

(Inner diameter: $\phi 4$ to $\phi 30$)

[For the Supported Side]

Square Type Model EF

Specification Table⇒ **A** 15-290

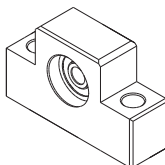

(Inner diameter: $\phi 6$ to $\phi 20$)

Square Type Model BF

Specification Table⇒ **A** 15-292

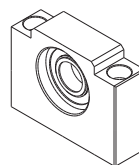

(Inner diameter: $\phi 8$ to $\phi 40$)

Round Type Model FF

Specification Table⇒ **A** 15-294

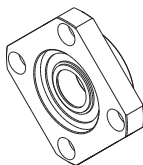

(Inner diameter: $\phi 6$ to $\phi 30$)

Types of Support Units and Applicable Screw Shaft Outer Diameters

Inner diameter of fixed-side Support Unit (mm)	Inner diameter of supported-side Support Unit (mm)	Applicable Model No. of fixed-side Support Unit	Applicable model No. of the supported side Support Unit	Type BNK with Unfinished Shaft Ends(Applicable Model No.)	Recommended Shapes of Shaft Ends(Applicable Shaft Outer Diameter ϕ D)	
					Shaft End H (mm)	Shaft End J (mm)
4	—	EK 4 FK 4	—	BNK0401 BNK0501	ϕ 6	—
5	—	EK 5 FK 5	—	BNK0601	ϕ 8	—
6	6	EK 6 FK 6	EF 6 FF 6	BNK0801 BNK0802 BNK0810	ϕ 8 ϕ 10	—
8	6	EK 8 FK 8	EF 8 FF 6	BNK1002	ϕ 12	—
10	8	EK 10 FK 10 BK 10	EF 10 FF 10 BF 10	BNK1004 BNK1010 BNK1202 BNK1205 BNK1208	ϕ 14 ϕ 15	ϕ 14 ϕ 15
12	10	EK 12 FK 12 BK 12	EF 12 FF 12 BF 12	BNK1402 BNK1404 BNK1408 BNK1510 BNK1520 BNK1616	ϕ 16 ϕ 18	ϕ 16 ϕ 18
15	15	EK 15 FK 15	EF 15 FF 15	BNK2010 BNK2020	ϕ 20 ϕ 25	—
		BK 15	BF 15	—	—	ϕ 20
17	17	BK 17	BF 17	—	—	ϕ 25
20	20	EK 20 FK 20	EF 20 FF 20	BNK2520	ϕ 28 ϕ 30 ϕ 32	—
		BK 20	BF 20	—	—	ϕ 28 ϕ 30 ϕ 32
25	25	FK 25	FF 25	—	ϕ 36	—
		BK 25	BF 25	—	—	ϕ 36
30	30	FK 30	FF 30	—	ϕ 40	ϕ 40
		BK 30	BF 30	—		
35	35	BK 35	BF 35	—	—	ϕ 45
40	40	BK 40	BF 40	—	—	ϕ 50 ϕ 55

Note1) The Supports Units in this table apply only to those Ball Screw models with recommended shaft ends shapes H, J and K, indicated on [A15-280](#).

Note2) For Recommended Shapes of Shaft Ends H, J, and K; refer to pages [A15-296](#) to [A15-301](#).

Model Numbers of Bearings and Characteristic Values

Angular ball bearing on the fixed side					Deep-groove ball bearing on the supported side			
Support Unit model No.	Bearing	Axial direction			Support Unit model No.	Bearing model No.	Radial direction	
		Basic dynamic load rating Ca (kN)	Note) Permissible load (kN)	Rigidity (N/ μ m)			Basic dynamic load rating C(kN)	Basic static load rating Co(kN)
EK 4 FK 4	AC4-12 (DF P5)	0.93	1.1	27	—	—	—	—
EK 5 FK 5	AC5-14 (DF P5)	1	1.24	29	—	—	—	—
EK 6 FK 6	AC6-16 (DF P5)	1.38	1.76	35	EF 6 FF 6	606ZZ	2.19	0.87
EK 8 FK 8	79M8A (DF P5)	2.93	2.15	49	EF 8	606ZZ	2.19	0.87
EK 10 FK 10 BK 10	7000 equivalent (DF P5)	6.08	3.1	65	EF 10 FF 10 BF 10	608ZZ	3.35	1.4
EK 12 FK 12 BK 12	7001 equivalent (DF P5)	6.66	3.25	88	EF 12 FF 12 BF 12	6000ZZ	4.55	1.96
EK 15 FK 15 BK 15	7002 equivalent (DF P5)	7.6	4	100	EF 15 FF 15 BF 15	6002ZZ	5.6	2.84
BK 17	7203 equivalent (DF P5)	13.7	5.85	125	BF 17	6203ZZ	9.6	4.6
EK 20 FK 20	7204 equivalent (DF P5)	17.9	9.5	170	EF 20 FF 20	6204ZZ	12.8	6.65
BK 20	7004 equivalent (DF P5)	12.7	7.55	140	BF 20	6004ZZ	9.4	5.05
FK 25 BK 25	7205 equivalent (DF P5)	20.2	11.5	190	FF 25 BF 25	6205ZZ	14	7.85
FK 30 BK 30	7206 equivalent (DF P5)	28	16.3	195	FF 30 BF 30	6206ZZ	19.5	11.3
BK 35	7207 equivalent (DF P5)	37.2	21.9	255	BF 35	6207ZZ	25.7	15.3
BK 40	7208 equivalent (DF P5)	44.1	27.1	270	BF 40	6208ZZ	29.1	17.8

Note) "Permissible load" indicates the static permissible load.

Example of Installation

[Square Type Support Unit]

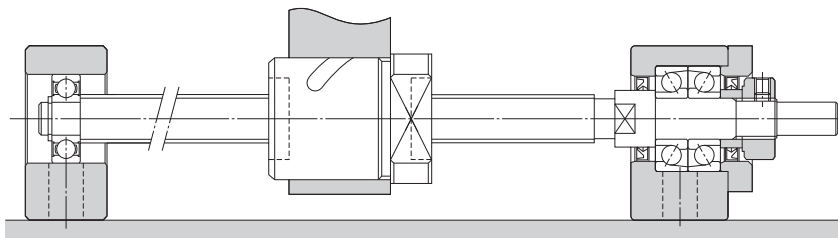

Fig.2 Example of Installing a Square Type Support Unit

[Round Type Support Unit]

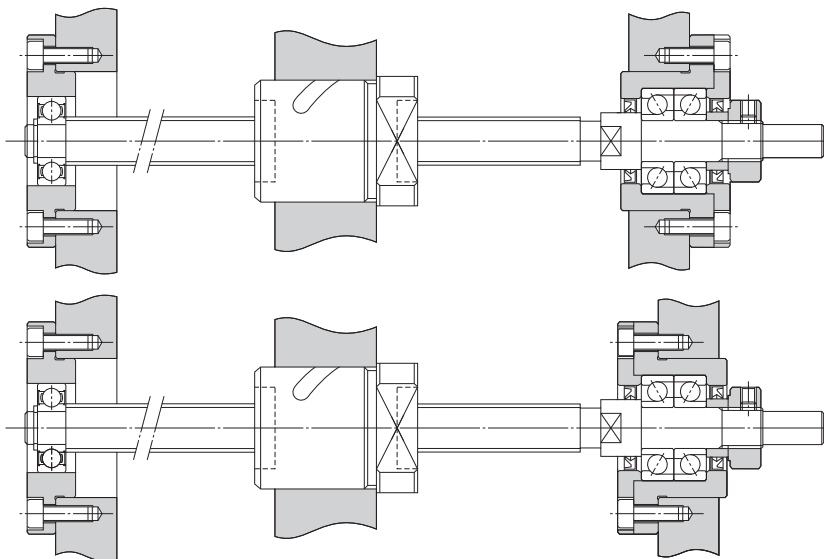

Fig.3 Example of Installing a Round Type Support Unit

Mounting Procedure

[Installing the Support Unit]

- (1) Install the fixed side Support Unit with the screw shaft.
- (2) After inserting the fixed side Support Unit, secure the lock nut using the fastening set piece and the hexagonal socket-head setscrews.
- (3) Attach the supported side bearing to the screw shaft and secure the bearing using the snap ring, and then install the assembly to the housing on the supported side.

Note1) Do not disassemble the Support Unit.

Note2) When inserting the screw shaft to the Support Unit, take care not to let the oil seal lip turn outward.

Note3) When securing the set piece with a hexagonal socket-head setscrew, apply an adhesive to the hexagonal socket-head setscrew before tightening it in order to prevent the screw from loosening. If planning to use the product in a harsh environment, it is also necessary to take a measure to prevent other components/parts from loosening. Contact THK for details.

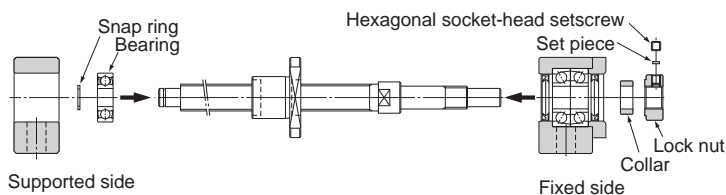

[Installation onto the Table and the Base]

- (1) If using a bracket when mounting the ball screw nut to the table, insert the nut into the bracket and temporarily fasten it.
- (2) Temporarily fasten the fixed side Support Unit to the base. In doing so, press the table toward the fixed side Support Unit to align the axial center, and adjust the table so that it can travel freely.
 - If using the fixed side Support Unit as the reference point, secure a clearance between the ball screw nut and the table or inside the bracket when making adjustment.
 - If using the table as the reference point, make the adjustment either by using the shim (for a square type Support Unit), or securing the clearance between the outer surface of the nut and the inner surface of the mounting section (for a round type Support Unit).
- (3) Press the table toward the fixed-side Support Unit to align the axial center. Make the adjustment by reciprocating the table several times so that the nut travels smoothly throughout the whole stroke, and temporarily secure the Support Unit to the base.

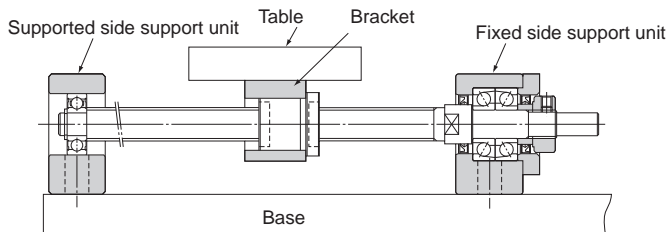

[Checking the Accuracy and Fully Fastening the Support Unit]

While checking the runout of the ball screw shaft end and the axial clearance using a dial gauge, fully fasten the ball screw nut, the nut bracket, the fixed side Support Unit and the supported-side Support Unit, in this order.

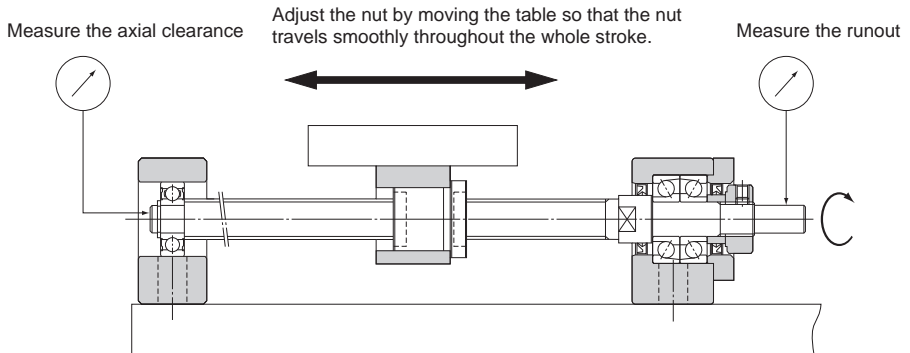

[Connection with the Motor]

- (1) Mount the motor bracket to the base.
- (2) Connect the motor and the ball screw using a coupling.

Note) Make sure the mounting accuracy is maintained.

- (3) Thoroughly perform the break-in for the system.

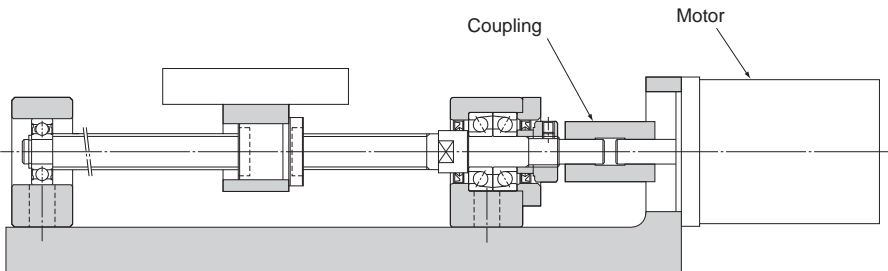

Types of Recommended Shapes of the Shaft Ends

To ensure speedy estimates and manufacturing of Ball Screws, THK has standardized the shaft end shapes of the screw shafts. The recommended shapes of shaft ends consist of shapes H, K and J, which allow standard Support Units to be used.

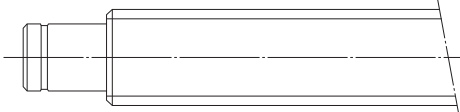
Mounting method	Symbol for shaft end shape	Shape	Supported Support Unit
Fixed	H J	H1	FK EK
		J1	BK
		H2	FK EK
		J2	BK
		H3	FK EK
		J3	BK
Supported	K		FF EF BF

EK Square Type Support Unit on the Fixed Side

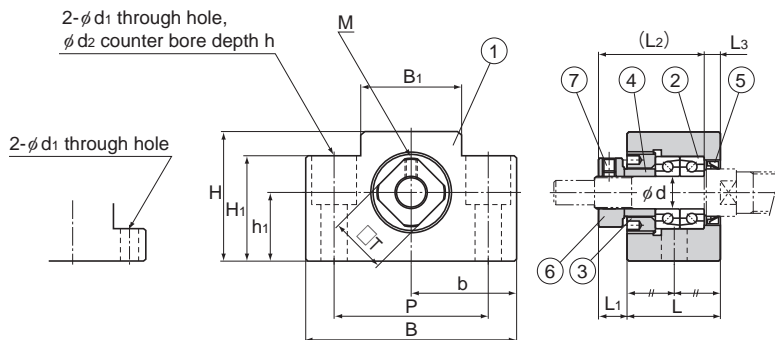

Models EK 4 and 5

Models EK 6 and 8

Model No.	Shaft diameter d	L	L ₁	L ₂	L ₃	B	H	b ±0.02
EK 4	4	15	5.5	17.5	3	34	19	17
EK 5	5	16.5	5.5	18.5	3.5	36	21	18
EK 6	6	20	5.5	22	3.5	42	25	21
EK 8	8	23	7	26	4	52	32	26
EK 10	10	24	6	29.5	6	70	43	35
EK 12	12	24	6	29.5	6	70	43	35
EK 15	15	25	6	36	5	80	49	40
EK 20	20	42	10	50	10	95	58	47.5

Models EK 4 to 8

Part No.	Part name	No. of units
1	Housing	1
2	Bearing	1 set
3	Set nut	1
4	Collar	2
5	Seal	1
6	Lock Nut	1
7	Hexagonal socket-head setscrew (with a set piece)	1

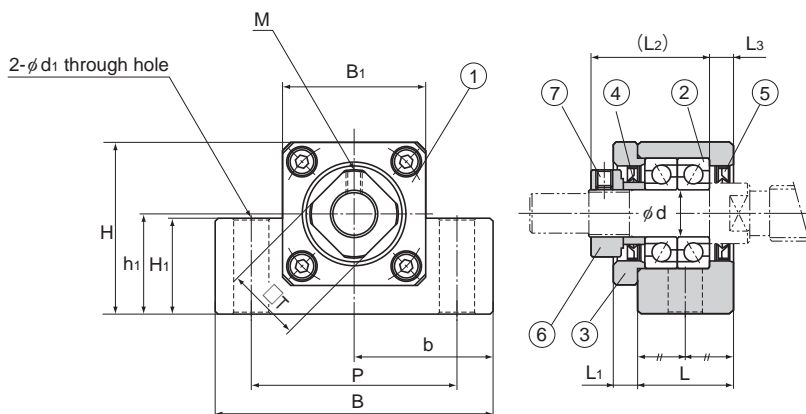

Models EK 10 to 20

Unit: mm

h_1 ± 0.02	B_1	H_1	P	d_1	d_2	h	M	T	Bearing used	Mass kg
10	18	7	26	4.5	—	—	M2.6	10	AC4-12(DF P5)	0.06
11	20	8	28	4.5	—	—	M2.6	11	AC5-14(DF P5)	0.08
13	18	20	30	5.5	9.5	11	M3	12	AC6-16(DF P5)	0.14
17	25	26	38	6.6	11	12	M3	14	79M8A(DF P5)	0.24
25	36	24	52	9	—	—	M3	16	7000 equivalent (DF P5)	0.46
25	36	24	52	9	—	—	M3	19	7001 equivalent (DF P5)	0.44
30	41	25	60	11	—	—	M3	22	7002 equivalent (DF P5)	0.55
30	56	25	75	11	—	—	M4	30	7204 equivalent (DF P5)	1.35

Models EK 10 to 20

Part No.	Part name	No. of units
1	Housing	1
2	Bearing	1 set
3	Holding lid	1
4	Collar	2
5	Seal	2
6	Lock Nut	1
7	Hexagonal socket-head setscrew (with a set piece)	1

BK Square Type Support Unit on the Fixed Side

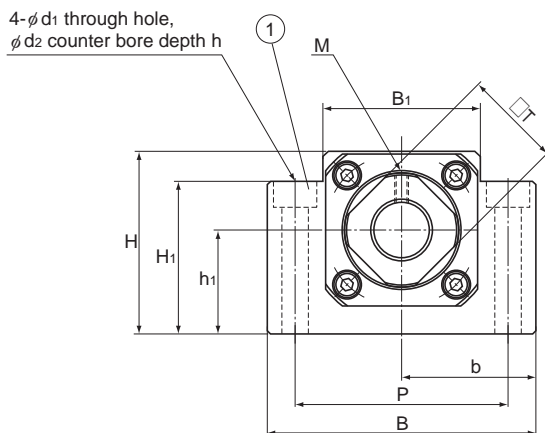

Model No.	Shaft diameter	L	L ₁	L ₂	L ₃	B	H	b ±0.02	h ₁ ±0.02	B ₁	H ₁
	d										
BK 10	10	25	5	29	5	60	39	30	22	34	32.5
BK 12	12	25	5	29	5	60	43	30	25	35	32.5
BK 15	15	27	6	32	6	70	48	35	28	40	38
BK 17	17	35	9	44	7	86	64	43	39	50	55
BK 20	20	35	8	43	8	88	60	44	34	52	50
BK 25	25	42	12	54	9	106	80	53	48	64	70
BK 30	30	45	14	61	9	128	89	64	51	76	78
BK 35	35	50	14	67	12	140	96	70	52	88	79
BK 40	40	61	18	76	15	160	110	80	60	100	90

FK Round Type Support Unit on the Fixed Side

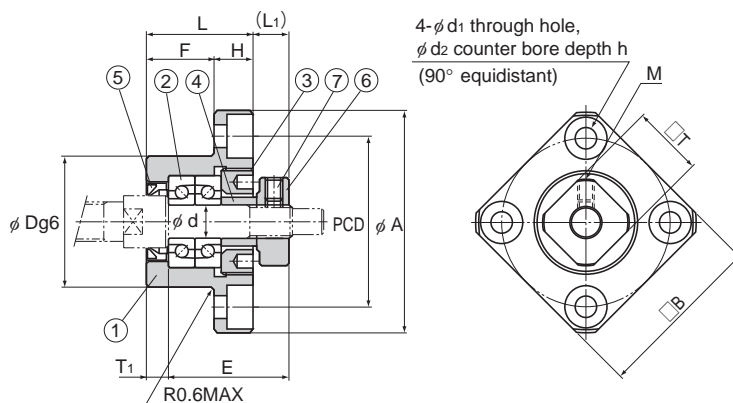

Mounting method A

Models FK 4 to 8

Model No.	Shaft diameter	L	H	F	E	D	A	PCD	B
	d								
FK 4	4	15	6	9	17.5	18 -0.006 -0.017	32	24	25
FK 5	5	16.5	6	10.5	18.5	20 -0.007 -0.02	34	26	26
FK 6	6	20	7	13	22	22 -0.007 -0.02	36	28	28
FK 8	8	23	9	14	26	28 -0.007 -0.02	43	35	35

Note) When using a Model BNK finished shaft end precision ball screw, use mounting method A only.

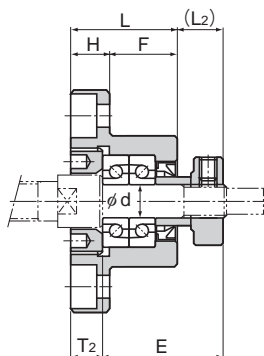

Mounting method B

Unit: mm

	Installation procedure A		Installation procedure B		d_1	d_2	h	M	T	Bearing used	Mass kg
	L_1	T_1	L_2	T_2							
	5.5	3	6.5	4	3.4	6.5	4	M2.6	10	AC4-12(DF P5)	0.05
	5.5	3.5	7	5	3.4	6.5	4	M2.6	11	AC5-14(DF P5)	0.06
	5.5	3.5	8.5	6.5	3.4	6.5	4	M3	12	AC6-16(DF P5)	0.08
	7	4	10	7	3.4	6.5	4	M3	14	79M8A(DF P5)	0.15

Part No.	Part name	No. of units
1	Housing	1
2	Bearing	1 set
3	Set nut	1
4	Collar	2
5	Seal	1
6	Lock Nut	1
7	Hexagonal socket-head setscrew (with a set piece)	1

FK Round Type Support Unit on the Fixed Side

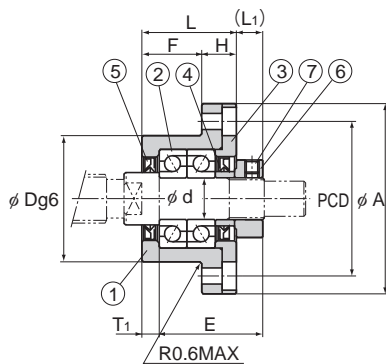

Mounting method A

4- ϕ d1 through hole,
 ϕ d2 counter bore depth h
 (90° equidistant)

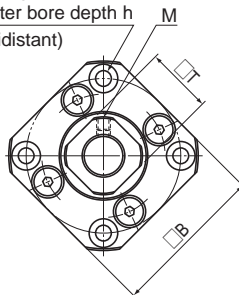

Models FK 10 to 30

Model No.	Shaft diameter	L	H	F	E	D	A	PCD	B
	d								
FK 10	10	27	10	17	29.5	34 -0.009 -0.025	52	42	42
FK 12	12	27	10	17	29.5	36 -0.009 -0.025	54	44	44
FK 15	15	32	15	17	36	40 -0.009 -0.025	63	50	52
FK 20	20	52	22	30	50	57 -0.01 -0.029	85	70	68
FK 25	25	57	27	30	60	63 -0.01 -0.029	98	80	79
FK 30	30	62	30	32	61	75 -0.01 -0.029	117	95	93

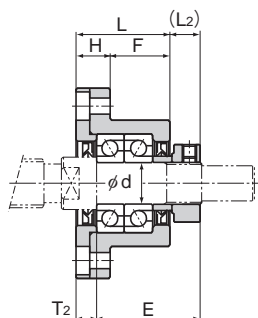

Mounting method B

Unit: mm

	Installation procedure A		Installation procedure B		d_1	d_2	h	M	T	Bearing used	Mass kg
	L_1	T_1	L_2	T_2							
	7.5	5	8.5	6	4.5	8	4	M3	16	7000 equivalent (DF P5)	0.21
	7.5	5	8.5	6	4.5	8	4	M3	19	7001 equivalent (DF P5)	0.22
	10	6	12	8	5.5	9.5	6	M3	22	7002 equivalent (DF P5)	0.39
	8	10	12	14	6.6	11	10	M4	30	7204 equivalent (DF P5)	1.09
	13	10	20	17	9	15	13	M5	35	7205 equivalent (DF P5)	1.49
	11	12	17	18	11	17.5	15	M6	40	7206 equivalent (DF P5)	2.32

Part No.	Part name	No. of units
1	Housing	1
2	Bearing	1 set
3	Holding lid	1
4	Collar	2
5	Seal	2
6	Lock Nut	1
7	Hexagonal socket-head setscrew (with a set piece)	1

EF Square Type Support Unit on the Supported Side

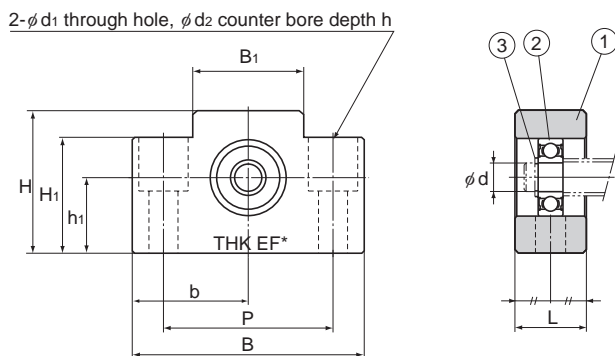

Models EF 6 and 8

Model No.	Shaft diameter d	L	B	H	b ± 0.02	h ₁ ± 0.02	B ₁
EF 6	6	12	42	25	21	13	18
EF 8	6	14	52	32	26	17	25
EF 10	8	20	70	43	35	25	36
EF 12	10	20	70	43	35	25	36
EF 15	15	20	80	49	40	30	41
EF 20	20	26	95	58	47.5	30	56

Note) The area marked with "*" is imprinted with a numeric character(s) as part of the model number.

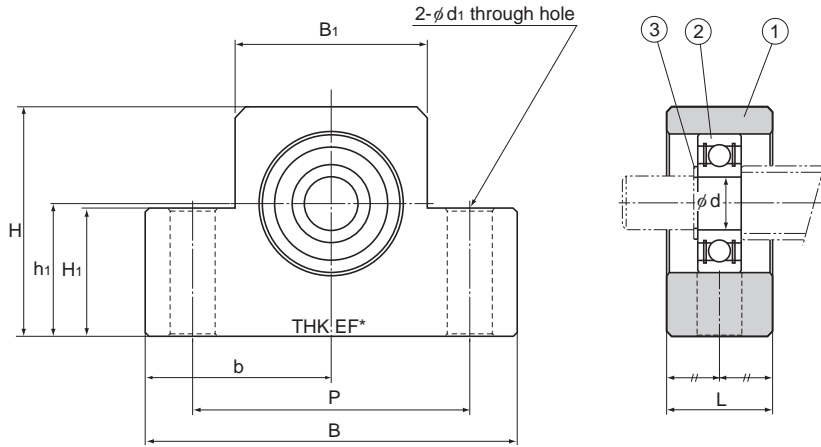

Models EF 10 to 20

Unit: mm

	H_1	P	d_1	d_2	h	Bearing used	Snap ring size	Mass kg
	20	30	5.5	9.5	11	606ZZ	C6	0.07
	26	38	6.6	11	12	606ZZ	C6	0.13
	24	52	9	—	—	608ZZ	C8	0.33
	24	52	9	—	—	6000ZZ	C10	0.32
	25	60	9	—	—	6002ZZ	C15	0.38
	25	75	11	—	—	6204ZZ	C20	0.63

Part No.	Part name	No. of units
1	Housing	1
2	Bearing	1
3	Snap ring	1

BF Square Type Support Unit on the Supported Side

2- ϕ d1 through hole,
 ϕ d2 counter bore depth h

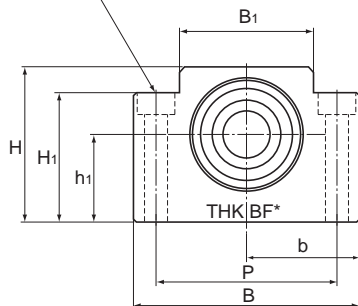

Model No.	Shaft diameter d	L	B	H	b ± 0.02	h ₁ ± 0.02	B ₁	H ₁
BF 10	8	20	60	39	30	22	34	32.5
BF 12	10	20	60	43	30	25	35	32.5
BF 15	15	20	70	48	35	28	40	38
BF 17	17	23	86	64	43	39	50	55
BF 20	20	26	88	60	44	34	52	50
BF 25	25	30	106	80	53	48	64	70
BF 30	30	32	128	89	64	51	76	78
BF 35	35	32	140	96	70	52	88	79
BF 40	40	37	160	110	80	60	100	90

Note) The area marked with "*" is imprinted with a numeric character(s) as part of the model number.

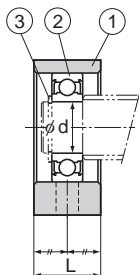

Unit: mm

	P	d_1	d_2	h	Bearing used	Snap ring used	Mass kg
	46	6.6	10.8	5	608ZZ	C8	0.29
	46	6.6	10.8	1.5	6000ZZ	C10	0.3
	54	6.6	11	6.5	6002ZZ	C15	0.38
	68	9	14	8.5	6203ZZ	C17	0.74
	70	9	14	8.5	6004ZZ	C20	0.76
	85	11	17.5	11	6205ZZ	C25	1.42
	102	14	20	13	6206ZZ	C30	1.97
	114	14	20	13	6207ZZ	C35	2.22
	130	18	26	17.5	6208ZZ	C40	3.27

Part No.	Part name	No. of units
1	Housing	1
2	Bearing	1
3	Snap ring	1

FF Round Type Support Unit on the Supported Side

4- ϕ d1 through hole,
 ϕ d2 counter bore depth h
 (90° equidistant)

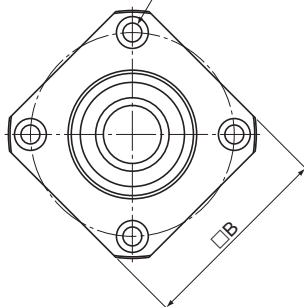

Model No.	Shaft diameter d	L	H	F	D	A
FF 6	6	10	6	4	22 -0.007 -0.02	36
FF 10	8	12	7	5	28 -0.007 -0.02	43
FF 12	10	15	7	8	34 -0.009 -0.025	52
FF 15	15	17	9	8	40 -0.009 -0.025	63
FF 20	20	20	11	9	57 -0.01 -0.029	85
FF 25	25	24	14	10	63 -0.01 -0.029	98
FF 30	30	27	18	9	75 -0.01 -0.029	117

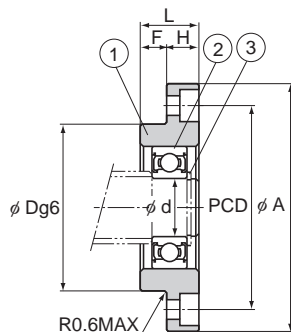

Unit: mm

	PCD	B	d_1	d_2	h	Bearing used	Snap ring used	Mass kg
	28	28	3.4	6.5	4	606ZZ	C6	0.04
	35	35	3.4	6.5	4	608ZZ	C8	0.07
	42	42	4.5	8	4	6000ZZ	C10	0.11
	50	52	5.5	9.5	5.5	6002ZZ	C15	0.2
	70	68	6.6	11	6.5	6204ZZ	C20	0.27
	80	79	9	14	8.5	6205ZZ	C25	0.67
	95	93	11	17.5	11	6206ZZ	C30	1.07

Part No.	Part name	No. of units
1	Housing	1
2	Bearing	1
3	Snap ring	1

Recommended Shapes of Shaft Ends - Shape H (H1, H2 and H3) (For Support Unit Models FK and EK)

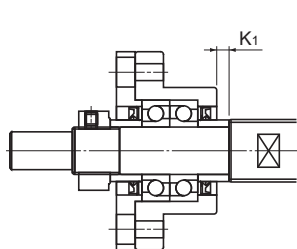

Model FK

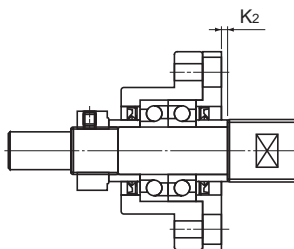

Model FK

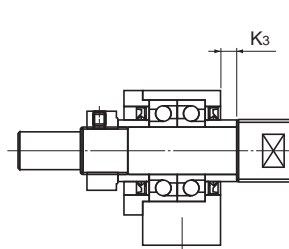

Model EK

Support Unit model No.		Ball screw shaft outer diameter	Shaft outer diameter of the bearing	B	E	F	Metric screw thread	
Model FK	Model EK						d	A
FK4	EK4	6	4	3	23	5	M4×0.5	7
FK5	EK5	8	5	4	25	6	M5×0.5	7
FK6	EK6	10*1	6	4	30	8	M6×0.75	8
FK8	EK8	12	8	6	35	9	M8×1	10
FK10	EK10	14	10	8	36	15	M10×1	11
FK10	EK10	15	10	8	36	15	M10×1	11
FK12	EK12	16	12	10	36	15	M12×1	11
FK12	EK12	18	12	10	36	15	M12×1	11
FK15	EK15	20	15	12	49	20	M15×1	13
FK15	EK15	25	15	12	49	20	M15×1	13
FK20	EK20	28	20	17	64	25	M20×1	17
FK20	EK20	30	20	17	64	25	M20×1	17
FK20	EK20	32	20	17	64	25	M20×1	17
FK25	—	36	25	20	76	30	M25×1.5	20
FK30	—	40	30	25	72	38	M30×1.5	25

Note) Support Units are designed to have dimensions so that combinations of models FK and FF, models EK and EF or models BK and BF are used on the same shaft.

If desiring the shaft end to be machined at THK, add the shape symbol in the end of the Ball Screw model number.

(Example) TS2505+500L-H2K

(Shape H2 on the fixed side; shape K on the supported side)

For the permissible radial runout of the shaft bearing end face, refer to JIS B 1192 (ISO 3408).

*1 FK6 and EK6 also support $\phi 8$ mm outer diameter ball screws. Contact THK for details.

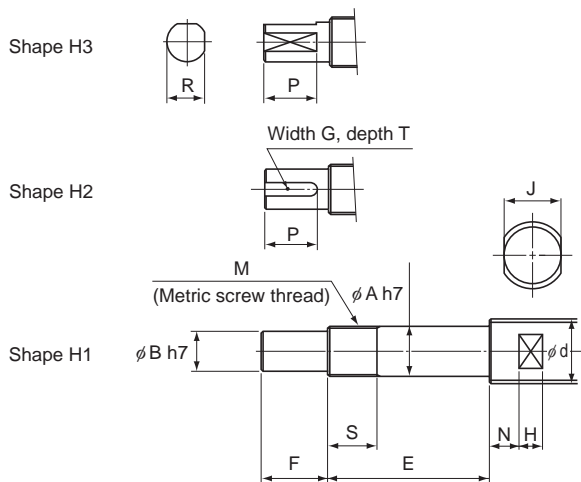

Unit: mm

	Width across flat			Shape H2 Keyway			Shape H3 Cut flat on two side		Support Unit position		
									Model FK		Model EK
	J	N	H	G N9	T +0.1 0	P	R	P	K ₁	K ₂	
	4	4	4	—	—	—	2.7	4	1.5	0.5	1.5
	5	4	4	—	—	—	3.7	5	2	0.5	2
	5	4	4	—	—	—	3.7	6	3.5	0.5	3.5
	8	5	5	—	—	—	5.6	7	3.5	0.5	3.5
	10	5	7	2	1.2	11	7.5	11	0.5	-0.5	-0.5
	10	5	7	2	1.2	11	7.5	11	0.5	-0.5	-0.5
	13	6	8	3	1.8	12	9.5	12	0.5	-0.5	-0.5
	13	6	8	3	1.8	12	9.5	12	0.5	-0.5	-0.5
	16	6	9	4	2.5	16	11.3	16	4	2	5
	18	7	10	4	2.5	16	11.3	16	4	2	5
	21	8	11	5	3	21	16	21	1	-3	1
	24	8	12	5	3	21	16	21	1	-3	1
	27	9	13	5	3	21	16	21	1	-3	1
	27	10	13	6	3.5	25	19	25	5	-2	—
	32	10	15	8	4	32	23.5	32	-3	-9	—

Note) The ball nut flange faces the fixed side unless otherwise specified.

If desiring the flange to face the supported side, add symbol G in the end of the Ball Screw model number when placing an order.

(Example) BIF2505-5RRGO+420LC5-H2KG

Recommended Shapes of Shaft Ends - Shape J (J1, J2 and J3) (For Support Unit Model BK)

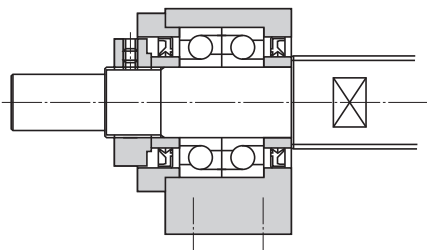

Model BK

Support Unit model No. Model BK	Ball screw shaft outer diameter d	Shaft outer diameter of the bearing A	B	E	F	Metric screw thread
						M
BK10	14	10	8	39	15	M10×1
BK10	15	10	8	39	15	M10×1
BK12	16	12	10	39	15	M12×1
BK12	18	12	10	39	15	M12×1
BK15	20	15	12	40	20	M15×1
BK17	25	17	15	53	23	M17×1
BK20	28	20	17	53	25	M20×1
BK20	30	20	17	53	25	M20×1
BK20	32	20	17	53	25	M20×1
BK25	36	25	20	65	30	M25×1.5
BK30	40	30	25	72	38	M30×1.5
BK35	45	35	30	83	45	M35×1.5
BK40	50	40	35	98	50	M40×1.5
BK40	55	40	35	98	50	M40×1.5

Note) Support Units are designed to have dimensions so that combinations of models FK and FF, models EK and EF or models BK and BF are used on the same shaft.

If desiring the shaft end to be machined at THK, add the shape symbol in the end of the Ball Screw model number.

(Example) TS2505+500L-J2K

(Shape J2 on the fixed side; shape K on the supported side)

For the permissible radial runout of the shaft bearing end face, refer to JIS B 1192 (ISO 3408).

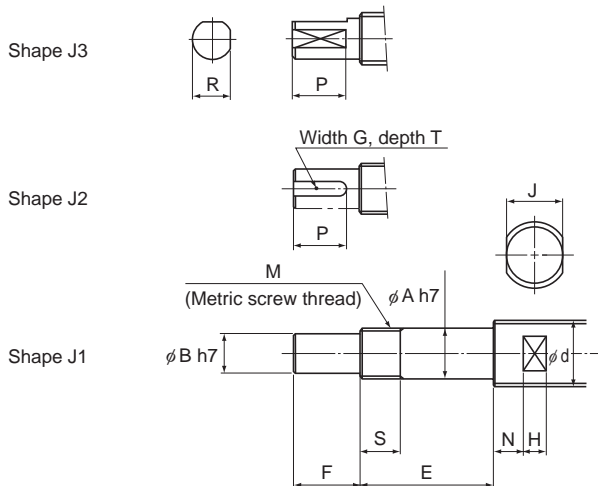

Unit: mm

	Width across flat				Shape J2 Keyway			Shape J3 Cut flat on two side	
	S	J	N	H	G N9	T +0.1 0	P	R	P
	16	10	5	7	2	1.2	11	7.5	11
	16	10	5	7	2	1.2	11	7.5	11
	14	13	6	8	3	1.8	12	9.5	12
	14	13	6	8	3	1.8	12	9.5	12
	12	16	6	9	4	2.5	16	11.3	16
	17	18	7	10	5	3	21	14.3	21
	15	21	8	11	5	3	21	16	21
	15	24	8	12	5	3	21	16	21
	15	27	9	13	5	3	21	16	21
	18	27	10	13	6	3.5	25	19	25
	25	32	10	15	8	4	32	23.5	32
	28	36	12	15	8	4	40	28.5	40
	35	41	14	19	10	5	45	33	45
	35	46	14	20	10	5	45	33	45

Note) The ball nut flange faces the fixed side unless otherwise specified.

If desiring the flange to face the supported side, add symbol G in the end of the Ball Screw model number when placing an order.

(Example) BIF2505-5RRGO+420LC5-J2KG

Recommended Shapes of Shaft Ends - Shape K (For Support Unit Models FF, EF and BF)

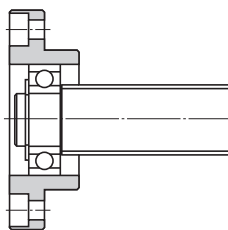

Model FF

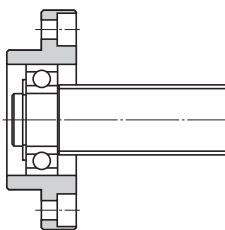

Model FF

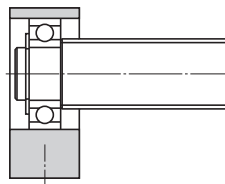

Model EF

Model BF

Support Unit model No.			Ball screw shaft outer diameter	Shaft outer diameter of the bearing
Model FF	Model EF	Model BF		
FF6	EF6	—	8	6
—	EF8	—	12	6
FF10	EF10	BF10	14	8
FF10	EF10	BF10	15	8
FF12	EF12	BF12	16	10
FF12	EF12	BF12	18	10
FF15	EF15	BF15	20	15
FF15	EF15	BF15	25	15
—	—	BF17 *		17
FF20	EF20	BF20 **	28	20
FF20	EF20	BF20 **	30	20
FF20	EF20	BF20 **	32	20
FF25	—	BF25	36	25
FF30	—	BF30	40	30
—	—	BF35	45	35
—	—	BF40	50	40
—	—	BF40	55	40

Note) Support Units are designed to have dimensions so that combinations of models FK and FF, models EK and EF or models BK and BF are used on the same shaft.

If desiring the shaft end to be machined at THK, add the shape symbol in the end of the Ball Screw model number.

(Example) TS2505+500L-H2K

(Shape H2 on the fixed side; shape K on the supported side)

For the permissible radial runoff of the shaft bearing end face, refer to JIS B 1192 (ISO 3408).

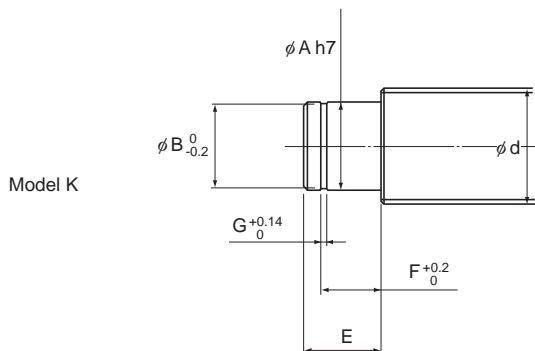

Unit: mm

E	Snap ring groove		
	B	F	G
9	5.7	6.8	0.8
9	5.7	6.8	0.8
10	7.6	7.9	0.9
10	7.6	7.9	0.9
11	9.6	9.15	1.15
11	9.6	9.15	1.15
13	14.3	10.15	1.15
13	14.3	10.15	1.15
16	16.2	13.15	1.15
19 (16)	19	15.35 (13.35)	1.35
19 (16)	19	15.35 (13.35)	1.35
19 (16)	19	15.35 (13.35)	1.35
20	23.9	16.35	1.35
21	28.6	17.75	1.75
22	33	18.75	1.75
23	38	19.95	1.95
23	38	19.95	1.95

Note) *When model BK17 (shaft end shape: J) is used on the fixed side for a Ball Screw with a shaft outer diameter of 25 mm, the shaft end shape on the supported side is that for model BF17.

**The dimensions in the parentheses in the table above are that of model BF20. They differ from those of models FF20 and EF20. When placing an order, be sure to specify the model number of the Support Unit to be used.